



**AVERY
DENNISON**

Fastener
Solutions

34" Extra Heavy Duty Cable Ties Marketing Specifications

For the following part numbers:

10049-0

10050-0

August 1, 2018

AVERY DENNISON MARKETING SPECIFICATION

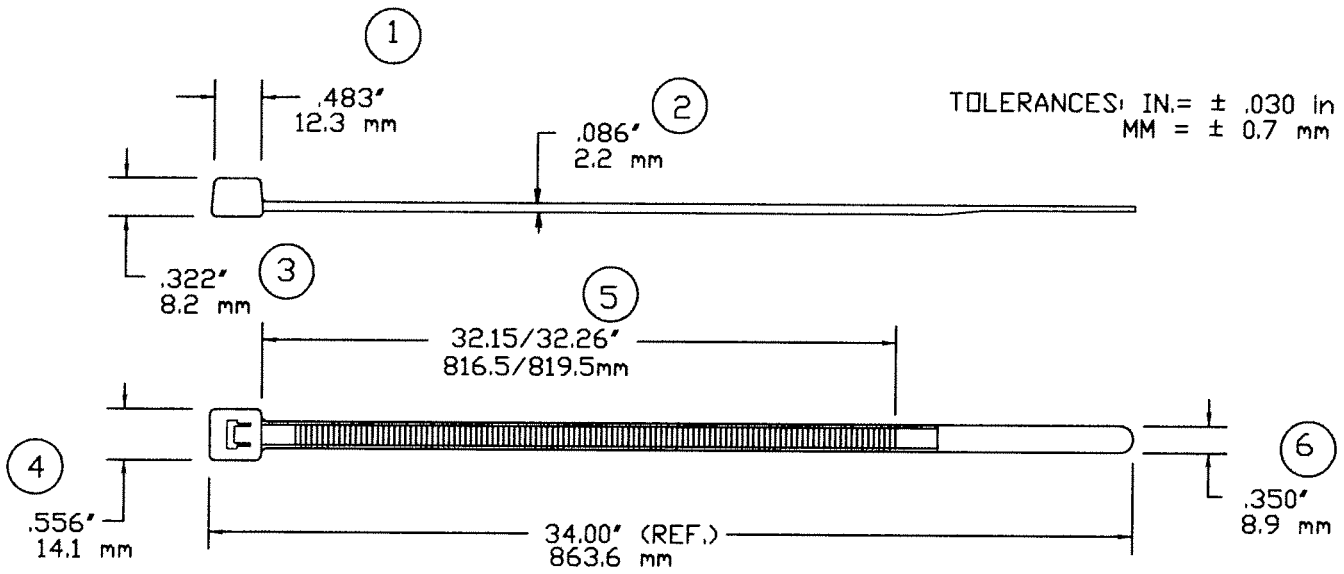

NOT TO SCALE

TENSILE STRENGTH:	175 lbs. / 79.7 kg. MINIMUM .
MILITARY STANDARD:	N/A
MATERIAL:	NYLON 6/6 PER MIL-M-20693 AND ASTM D4066
WEIGHT:	.595 oz. / 17.50 grams
BUNDLE DIAMETER:	1/4" - 10" RELEASABLE DESIGN
UL RECOGNIZED:	FILE NO. E57800
APPLICATION TOOL:	HAND APPLIED OR WITH AN EXTRA HEAVY DUTY TOOL. AVERY DENNISON PART NUMBER 10256
TOOL TENSION SETTING:	6-8
PACKAGED IN:	50 PACKS IN SEALED BAGS

STK.NO	DESCRIPTION
10049	NATURAL, TYPE I



FASTENER DIVISION
 FITCHBURG, MA 01420 U.S.A.
 TEL. 1-800-225-5913
 MA. 978-353-8157



DESCRIPTION:

34" CABLE TIE,
EXTRA HEAVY DUTY

APPROVAL:

James C. Beard 7-10-2019

STOCK NO.

10049

REV
H

AVERY DENNISON MARKETING SPECIFICATION

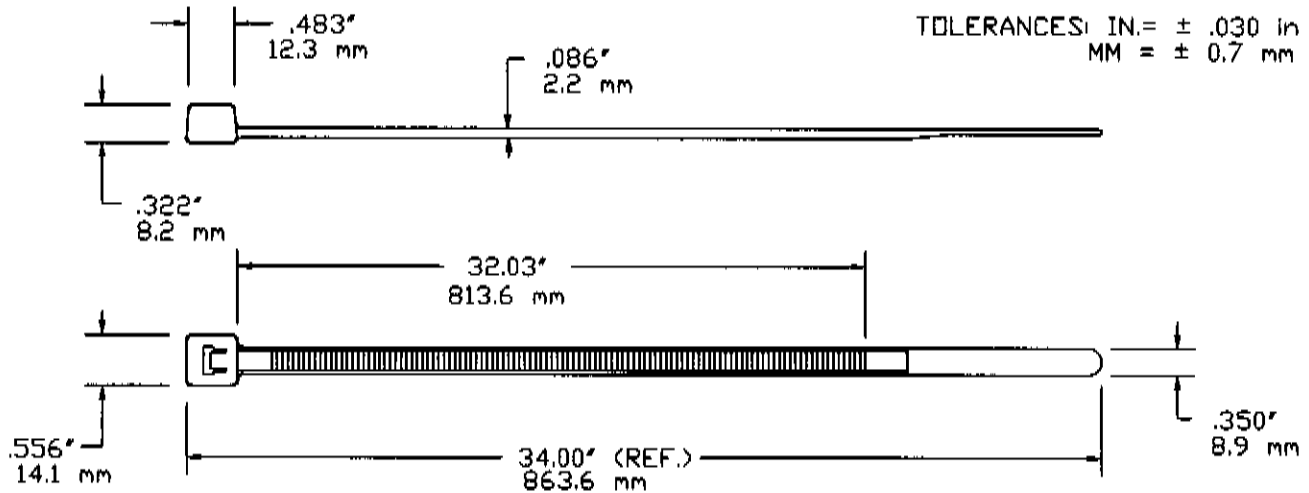

NOT TO SCALE

TENSILE STRENGTH:	175 lbs. / 79.7 kg. MINIMUM .
MILITARY STANDARD:	N/A
MATERIAL:	NYLON 6/6 PER ASTM D4066
WEIGHT:	.595 oz. / 17.50 grams
BUNDLE DIAMETER:	1/4" - 10" RELEASABLE DESIGN
UL RECOGNIZED:	FILE NO. E57800
APPLICATION TOOL:	HAND APPLIED OR WITH AN EXTRA HEAVY DUTY TOOL. AVERY DENNISON PART NUMBER 10256
TOOL TENSION SETTING:	6-8
PACKAGED IN:	50 PACKS IN SEALED BAGS

STK.NO	DESCRIPTION
10050	BLACK WEATHER RESISTANT TYPE II



FASTENER DIVISION
 FITCHBURG, MA 01420 U.S.A.
 TEL. 1-800-225-5913
 MA. 978-353-8157



DESCRIPTION:

**34" CABLE TIE,
EXTRA HEAVY DUTY**

APPROVAL:

J. Boyle 2-15-06

STOCK NO.

10050

REV

G